

EPIC STEEL 3' TUF RIB

3' TUF RIB INSTALLATION GUIDE



EPIC STEEL

TUF RIB

Table of Contents

General Notes

Claims	1
Returns	1
Storage	1
Handling	1
Foot Traffic	1
Safety	2
Field Cutting Panels	2
Condition of Substrate and Structure	2
Tools & Equipment	3
Roof Maintenance	3
Paint Warranty	3
Installation	4
Fastener and Selection Guide	5-6
Material Specifications	7

Flashing Details

Trim Profiles	8-9
Vented Ridge Cap	10
Non - Vented Ridge Cap	10
Hip / Ridge	11
High Eave	11
Gable	12
Eave	12
F & J Trim/ ½" J Trim	13
Endwall	13
Sidewall	14
Snow Stop	14
Inside Corner	15
Outside Corner	15
L-Base / Drip Cap	16
Upper Transition	16
Lower Transition	17
W-Valley	17
Angle Base	18
Wainscot / Z-Flashing	18
Cannonball Track Cover	19
Square Base	19
Overall Dormer	20
Ridge Tie-In	21
Valley-Tie-In	21

EPIC STEEL

TUF RIB

INFORMATION

This guide has been provided as a reference and helpful tool for installing Epic Steel's 3' Tuf Rib Panel. The installation details shown may not apply to all building designs, codes, or product applications. It is the responsibility of the installer to ensure the details meet code in his/her area.

Epic Steel reserves the right to change any information in this guide, at any time, without notice. If you have any questions or concerns, please contact your Epic Steel representative.

CLAIMS

It is the responsibility of the customer to review the condition and quantities of an order upon pick up or delivery. Claims for any shortages or damages must be filed immediately for orders picked up, or within 7 days for orders delivered. Epic Steel will not be held responsible for any claims filed after these time frames.

RETURNS

Epic Steel does not accept returns of any custom ordered materials, special ordered accessories, or fabricated metal products. Only stock accessories may be returned if they are deemed to be in resalable condition. Stock items being screws (full bag quantities), flashers, closures, clips, underlayment, etc. A restocking fee of 15% may be applied to all returned merchandise.

STORAGE

If the metal panels or trim are not used immediately, the metal should be stored in a well ventilated, cool, dry place. This will inhibit moisture build up on the panels and trim, which can lead to white rust.

If the product cannot be stored indoors, elevate one end of the bundle to allow any moisture to run off the panels. Also, a tarp should be loosely wrapped around the bundle, ensuring there is good air flow around the panels. Never store panels in direct contact with the ground.

Epic Steel assumes no responsibility for materials that are not stored properly.

HANDLING

Handle all panels and trim with care to avoid damage. When unbundling panels, do not drag one panel against another. This can cause scratches across the panels. When moving the panels, they should be carried vertically to the ground by grasping the edge of the panel carefully to ensure that no excessive bending occurs. Note, the edge of the panel is sharp, and gloves should always be worn when handling all metal.

When handling trim it is important to do so with care and ease. Many trim profiles are fragile and can be easily damaged if not handled appropriately. It is recommended that the installer or whomever is handling trim wear gloves and use two hands at all times.

FOOT TRAFFIC

Care of metal panels and trim must be exercised throughout installation. Foot Traffic can cause distortion of the panel and damage the finish. Foot traffic should be kept to an absolute minimum. Installers should wear soft soled shoes that will help with traction on the roof and prevent scratching.

When walking on the panels is unavoidable, walk in the flats only. Walking on the major ribs can damage the panel.

EPIC STEEL

TUF RIB

SAFETY

Safety should be the main concern when installing any metal project. Each job site presents different hazards, on the ground and the roof; therefore, it is the responsibility of the installer to determine the safest way to install the metal.

Personal protective equipment should be used at all times when handling or installing metal panels and trim (i.e. gloves, safety glasses, pants, long sleeved shirts and hard hats).

Always be aware of your surroundings and use fall protection. Never install metal roofing during windy or stormy days. Metal roofing can become slippery when wet or dusty and extra care needs to be taken if these conditions are present. Wind can create hazardous working situations by getting under the metal panel and pulling the installer off the roof. Metal roofing is very sharp and can cause serious bodily injury if handled inappropriately.

If a safety concern exists on a job site, stop work immediately. Always comply with OSHA safety regulations.

FIELD CUTTING PANELS

Tin Snips, a circular saw, or a nibbler is recommended for field cutting metal panels and trim. Always wear eye and ear protection when cutting metal. When cutting painted metal, ensure the metal particles and fragments do not end up on the painted surface. Metal particles on the painted surface will result in rusting and pitting in that area. Epic Steel recommends the panels to be turned upside down and all cutting be done looking at the backside of the material. Installers should immediately wipe away any debris from the material after cuts to prevent this problem. Panels should be cut in an area where metal particles do not end up on other panels or building materials.

Failure to remove the metal particles from the panel will void any warranty

CONDITION OF SUBSTRATE AND STRUCTURE

Before the installation process begins, it is critical that the framing and substrate are inspected to ensure that the structure is square and plumb. If it is not, it will have to be corrected. Make sure any structural fixes are done by someone with the proper experience and knowledge. Correct any objectionable warp, waves, or buckles in the substrate before proceeding with panel installation. The roof panels will follow the contour of the structure and may appear irregular if not corrected.

To check the structure for squareness, take two diagonal measurements from the corner to corner. The roof is square if the two measurements are equal.

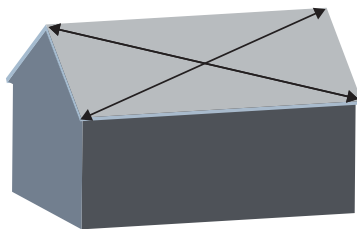

If the roof is not square, follow the 3-4-5 method to ensure that the panel is being installed square. If the first panel is not installed square, all remaining panels will also be out of square when attached to the structure.

- 1.) To do this, pick a starting point at the bottom corner of the roof, about a foot away. Set a nail there.
- 2.) From the nail, measure exactly 3 feet in the opposite direction along the bottom edge of the roof. Insert another nail in that spot.
- 3.) From the first nail, measure exactly 4 feet up the slope of the roof and draw a small arc.
- 4.) Measure from the second nail up to the arc measuring exactly 5 feet, drawing another arc.
- 5.) Attach a chalk line to the first nail and extend it up the slope to it passes through the intersection of the two arcs.
- 6.) Snap the chalk line. This line is now square with the bottom edge of the roof .
- 7.) Use this line to properly install the first panel square on the roof.¹

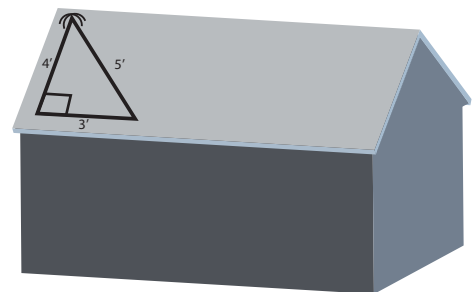

¹For larger roofs, this method can be done with multiples of 3,4,5 Example 6', 8', 10'

EPIC STEEL

TUF RIB

TOOLS & EQUIPMENT

- Hard Hat
- Gloves
- Safety Glasses
- Ear Plugs
- Fall Protection
- Screw Gun
- Tin Snips
- Tape Measure
- Chalk Line
- Electric Nibbler
- Circular Saw
- Angle Grinder
- Rivet Gun

ROOF MAINTENANCE

Roof maintenance should be done, at the minimum, annually. These steps will ensure that your roof will have a longer lifespan with less maintenance and help prevent costly repairs. It is best to perform roof maintenance when the weather permits safe working conditions.

- Clear all debris off the roof (dirt, rocks, branches, leaves, etc.)
- Clean out all drains and gutters to ensure proper drainage, to prevent water standing.
- Remove any overhanging branches or anything else that could penetrate the roof surface.
- Inspect all areas for leaks and deterioration - pay attention to stains and discoloration of the roof edges and surrounding walls as they are possible indications of a leak.
- Check roof penetrations for possible leaks and cracks in caulking.
- If exposed fasteners have been used to install the roof, it is crucial they are inspected annually.
 1. Check if they are installed correctly.
 2. Ensure that they are not fastened too tight or not tight enough.
 3. Inspect the integrity of the neoprene washer.

Refer to Fastener selection guide on the following pages 5-6.

PAINT WARRANTY

Warrant documents are available upon written request.

Please provide the following information to your local Epic Steel branch.

Product purchased - Including: panel type, width, color and gauge.

Where the product was purchased: Lumber yard, roofing wholesaler, contractor or direct.

When the product was purchased: Date of purchase (must be within 90 days of purchase date)

Owners Name and Contact Information:

Project Location: Physical address

Job Completion Date:

EPIC STEEL TUF RIB

INSTALLATION

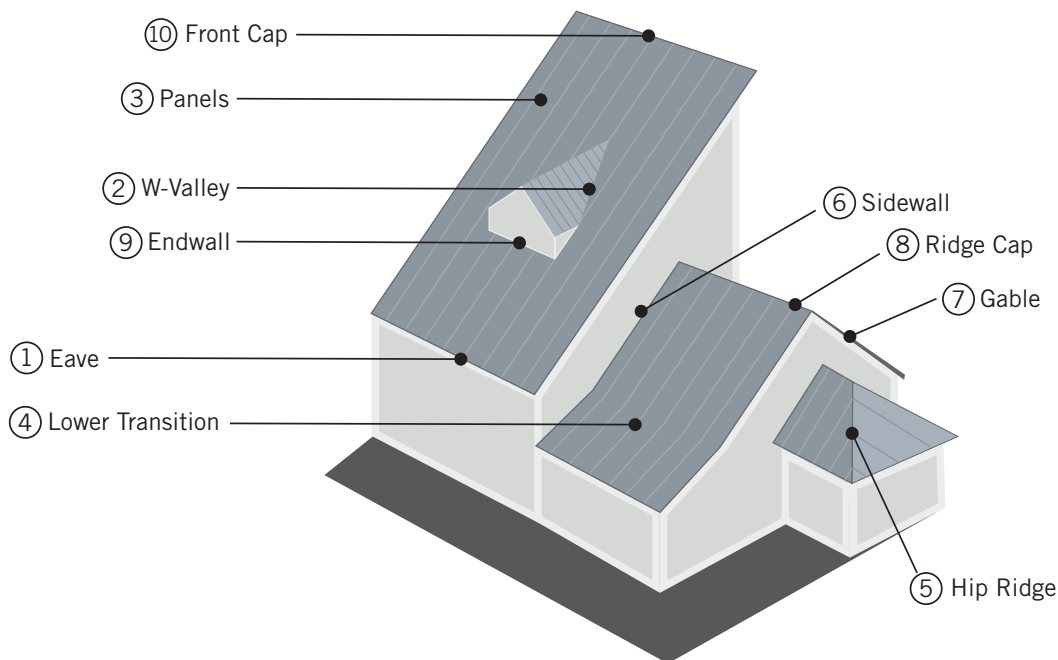

Installation over shingles is possible but is not recommended. It is best to remove shingles and install a new, synthetic underlayment to act as a vapor barrier between the substrate and the metal. If shingles will not be removed, furring strips need to be installed on the roof at 2'-0" centers. The metal panels will then be fastened to the furring strips.

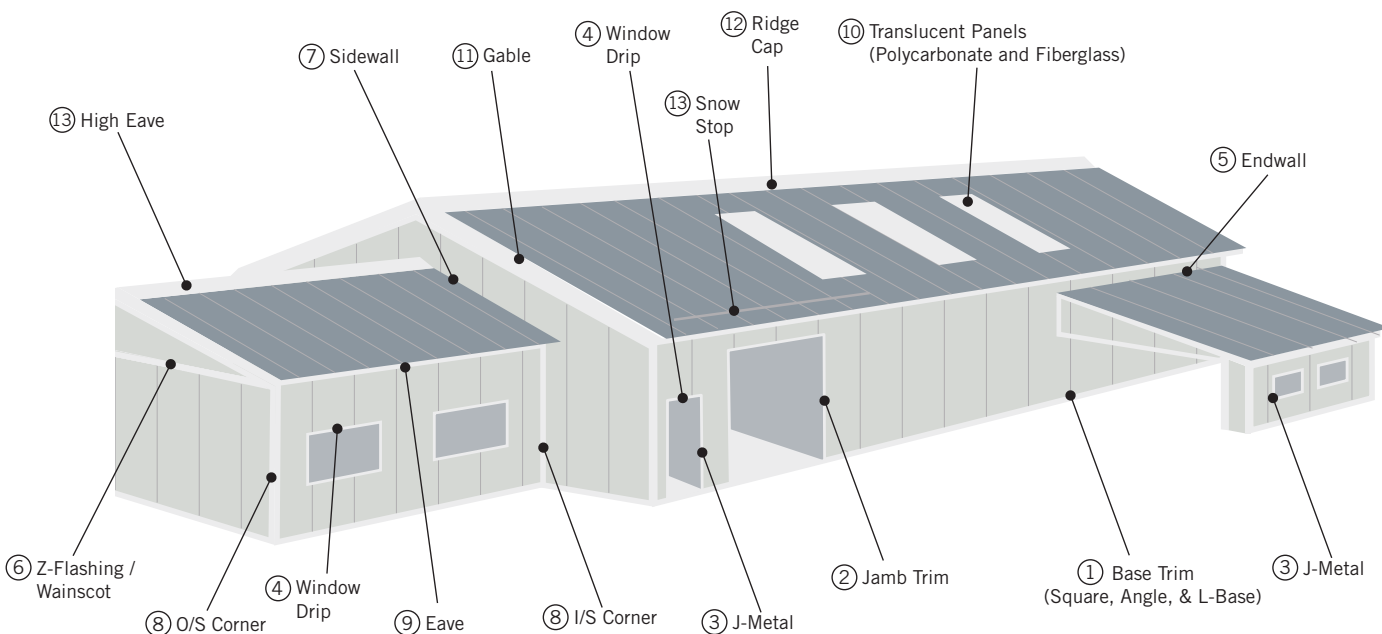

**Components are listed in the order that they are installed.*

**Please contact us for more information.*

EPIC STEEL

FASTENER SELECTION GUIDE

WOODFAST SCREW

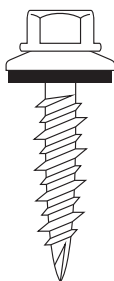

- No. 10 x 15, Type 17
- Available sizes: 1", 1 1/2", 2", 2 1/2", 3"
- 1/4" Hex Head
- Use: Panel to dimensional lumber and trim attachment.

WAFER SCREW

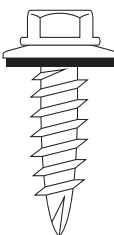

- No. 14 x 10, Type 17
- Available sizes: 1", 1 1/2", 2"
- 5/16" Hex Head
- Use: Panel to plywood/OSB substrate and trim attachment.

STITCH SCREW

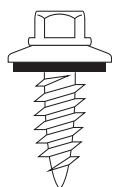

- No. 12 x 14
 - Available size: 3/4"
 - 1/4" Hex Head
 - Use: Trim attachment and stitching lap seams together (29 gauge).
- *Compatible with No. 10 & No. 14 Wood Screws*

TEK SCREW

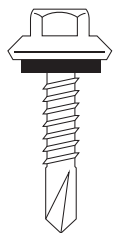

- No. 12 x 14
- Available sizes: 1", 1 1/2", 2"
- 5/16" Hex Head
- Use : Panel to Purlin (up to 3/16" steel).

PROPER INSTALLATION OF GASKETED FASTENERS



CORRECTLY DRIVEN

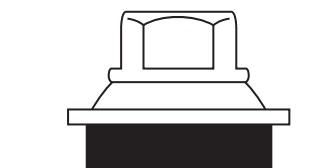

UNDER DRIVEN

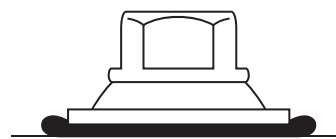

OVER DRIVEN

- This table shows the fasteners available for Epic Steel. Refer to the panel installation and flashing details of this manual for specific screw usage and spacing.
- Panel attachment screws must be long enough to fully penetrate through the wood roof decking, steel purlins or penetrate solid lumber at least one inch.
- All screws must be coated to provide protection against corrosion.
- Exposed fasteners must have sealing washers and should be the same color as the parts they attach.
- Screws must be properly driven to ensure proper seal and holding strength. Do not underdrive or overdrive the screws.
- Stainless steel rivets are not watertight.

EPIC STEEL

FASTENER SELECTION GUIDE

LAP TEK



- No. 14 x 7/8"
- Available size: 7/8"
- 5/16" Hex Head
- Use: Trim attachment and stitching lap Seams together .

**Compatible with No. 12 Tek Screw and No. 14 Wafer Screw*

TEK 5

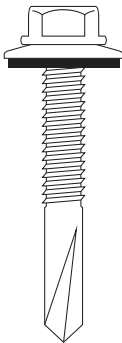

- No. 14 x 24
- Available size: 1 1/4"
- 5/16" Hex Head
- Use: Panel to purlin (Heavy Gauge Steel 3/16" and greater).

**Only Available in white and galvanized, remaining colors available by special order.*

PANHEAD

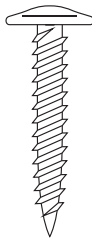

- 10 x 12
- Available sizes: 1", (1 1/2" and 2" available by special order)
- Phillips Head
- Use: To fasten standing seam panels and trim to wood deck (unexposed).

STAINLESS STEEL RIVET POP RIVET



- Available sizes: 1/8" x 3/16"
- Use: Trim attachment

PROPER INSTALLATION OF GASKETED FASTENERS

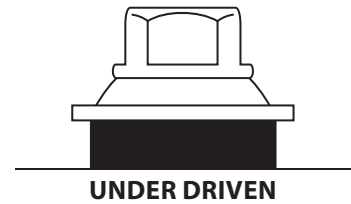

- This table shows the fasteners required for Epic Steel. Refer to the panel installation and flashing details of this manual for specific screw usage and spacing.
- Panel attachment screws must be long enough to fully penetrate through the wood roof decking, steel purlins or penetrate solid lumber at least one inch.
- All screws must be coated to provide protection against corrosion.
- Exposed fasteners must have sealing washers and should be the same color as the parts they attach.
- Screws must be properly driven to ensure proper seal and holding strength. Do not underdrive or overdrive the screws.
- Stainless steel rivets are not watertight.

EPIC STEEL TUF RIB

MATERIAL SPECIFICATIONS

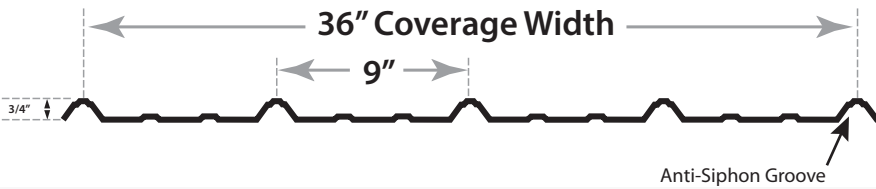

Available Gauges: 28 & 26

Weight: 1.98lbs/LnFt (28), 2.67lbs/LnFt (26)

Substrate: AZ50/AZ55, Grade 80

Available Materials: Painted & Galvalume

Paint System: Ceranamel XT - 40S
Certified Cool, Silicone
Modified Polyester

Warranties: Ceranamel XT - 40S – 40 Years
Galvalume – 25 years

Minimum Slope: 3:12

Testing:



- UL 580 Wind Uplift (Class 90)
- UL 2218 Class 4 Hail Impact
- UL 790 Class A Fire Rating

LOAD TABLES

29 Gauge thickness								
Span Type	Load Type	Support Spacing						
		2 Ft.	2.5 Ft.	3 Ft.	3.5 Ft.	4 Ft.	4.5 Ft.	5 Ft.
1-span	NEGATIVE WIND LOAD	76.55	48.99	34.02	25.00	19.14	15.12	12.25
	LIVE LOAD/DEFLECTION - L/60	99.36	63.59	44.16	32.45	24.84	19.63	15.90
	LIVE LOAD/DEFLECTION - L/180	86.19	44.13	25.54	16.08	10.77	7.57	5.52
	LIVE LOAD/DEFLECTION - L/240	64.64	33.10	19.15	12.06	8.08	5.67	4.14
2-span	NEGATIVE WIND LOAD	93.95	61.31	43.04	31.84	24.48	19.40	15.75
	LIVE LOAD/DEFLECTION - L/60	73.99	47.92	33.50	24.71	18.97	15.02	12.18
	LIVE LOAD/DEFLECTION - L/180	73.99	47.92	33.50	24.71	18.97	15.02	12.18
	LIVE LOAD/DEFLECTION - L/240	73.99	47.92	33.50	24.71	18.97	14.32	10.44
3-span	NEGATIVE WIND LOAD	114.79	75.48	53.16	39.06	29.90	23.63	19.14
	LIVE LOAD/DEFLECTION - L/60	86.59	59.35	41.60	30.74	23.62	18.71	15.19
	LIVE LOAD/DEFLECTION - L/180	86.59	59.35	41.60	30.74	21.00	14.75	10.75
	LIVE LOAD/DEFLECTION - L/240	86.59	59.35	37.34	23.51	15.75	11.06	8.07
4-span	NEGATIVE WIND LOAD	107.99	70.82	49.86	36.95	28.44	22.56	18.33
	LIVE LOAD/DEFLECTION - L/60	83.35	55.57	38.92	28.74	22.08	17.49	14.19
	LIVE LOAD/DEFLECTION - L/180	83.35	55.57	38.92	28.74	22.08	15.73	11.47
	LIVE LOAD/DEFLECTION - L/240	83.35	55.57	38.92	25.07	16.80	11.80	8.60

26 Gauge thickness								
Span Type	Load Type	Support Spacing						
		2 Ft.	2.5 Ft.	3 Ft.	3.5 Ft.	4 Ft.	4.5 Ft.	5 Ft.
1-span	NEGATIVE WIND LOAD	110.60	70.79	49.16	36.12	27.65	21.85	17.70
	LIVE LOAD/DEFLECTION - L/60	142.30	91.07	63.24	46.46	35.57	28.11	22.77
	LIVE LOAD/DEFLECTION - L/180	120.15	61.52	35.60	22.42	15.02	10.55	7.69
	LIVE LOAD/DEFLECTION - L/240	90.11	46.14	26.70	16.81	11.26	7.91	5.77
2-span	NEGATIVE WIND LOAD	133.88	87.51	61.50	45.51	35.01	27.76	22.54
	LIVE LOAD/DEFLECTION - L/60	106.51	69.08	48.32	35.66	27.38	21.68	17.59
	LIVE LOAD/DEFLECTION - L/180	106.51	69.08	48.32	35.66	27.38	21.68	17.59
	LIVE LOAD/DEFLECTION - L/240	106.51	69.08	48.32	35.66	27.38	19.84	14.46
3-span	NEGATIVE WIND LOAD	163.28	107.59	75.97	56.39	43.20	34.14	27.65
	LIVE LOAD/DEFLECTION - L/60	131.06	85.45	59.96	44.34	34.09	27.01	21.92
	LIVE LOAD/DEFLECTION - L/180	131.06	85.45	59.96	43.78	29.33	20.60	15.02
	LIVE LOAD/DEFLECTION - L/240	131.06	85.45	52.14	32.83	22.00	15.45	11.26
4-span	NEGATIVE WIND LOAD	153.71	101.00	71.20	52.79	40.67	32.27	26.22
	LIVE LOAD/DEFLECTION - L/60	123.00	80.05	56.11	41.46	31.86	25.24	20.48
	LIVE LOAD/DEFLECTION - L/180	123.00	80.05	56.11	41.46	31.20	21.91	15.98
	LIVE LOAD/DEFLECTION - L/240	123.00	80.05	55.47	34.93	23.40	16.44	11.98

***Notes:**

1. Strength Calculations based on the 2012 AISI Standard "North American Specification for the Design of Cold-formed Steel Structural Members."
2. Allowable loads are applicable for uniform loading and spans without overhangs.
3. LIVE LOAD/DEFLECTION load capacities are for those loads that push the panel against its support. The applicable limit states are flexure, shear, combined shear and flexure, web crippling at end and interior supports, and a deflection limit of L/180 under strength-level loads.
4. NEGATIVE WIND LOAD capacities are for those loads that pull the panel away from its supports. The applicable limit states are flexure, shear, combined shear and flexure, and a deflection limit of L/60 under 10-year wind loading.
5. Panel pullover and Screw pullout capacity must be checked separately using the screws employed for each particular application when utilizing this load chart.
6. Effective yield strength has been determined in accordance with section A2.3.2 of the 2012 NAS specification.
7. The use of any accessories other than those provided by the manufacturer may damage panels, void all warranties and will void all engineering data.
8. This material is subject to change without notice please contact Flatiron Steel for most current data.

The Engineering data contained herein is for the expressed use of customers and design professionals. Along with this data, it is recommended that the design professional have a copy of the most current version of the **North American Specification for the Design of Cold-Formed Steel Structural Members** published by the American Iron and Steel Institute to facilitate design. The Specification contains the design criteria for cold formed steel components. Along with the Specification, the designer should reference the most current building code applicable to the project jobsite in order to determine environmental loads. If further information or guidance regarding cold-formed design practices is desired, please contact the manufacturer.

Screw Patterns:

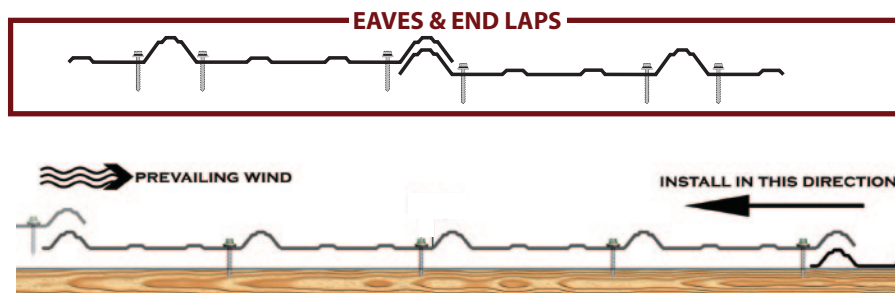

APPLICATION DETAILS

Fastener Guide:

- #10 Woodfast screws are designed for use with dimensional lumber
- #14 Wafer screws are designed for use with plywood sheathing, OSB, and wafer wood (7/16" minimum thickness)
- #12 Tek Screws are designed to be used with structural steel up to 3/16" in thickness

Fastener Application:

Screws are to be applied next to every rib and then up the panel, no more than 2'0". On low slope roofs, Mastic Tape must be applied between the panel side laps with Stitch Screws installed every 1'0" up the panel. ****At the eave or end laps, a double screw pattern should be used with screws applied to both sides of the rib****

Please Note: It is the responsibility of the builder to ensure that purlins are adequately spaced to meet specific engineering requirements.

****Epic Steel is neither partially or solely responsible for improper installation or defects as a result of installation****

EPIC STEEL

TUF RIB

TRIM PROFILES

28 GA.
(10'1" / Stick)

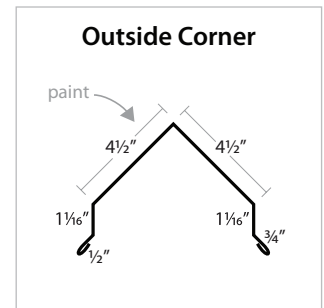
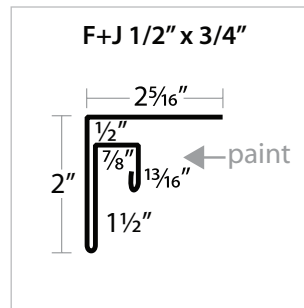
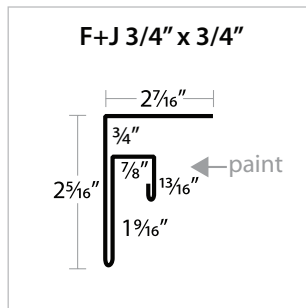
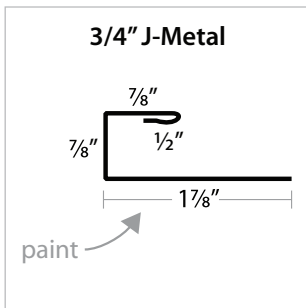
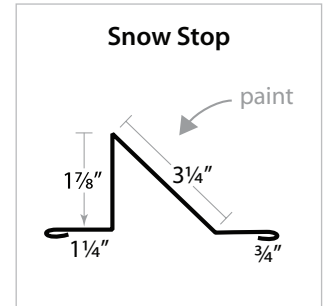
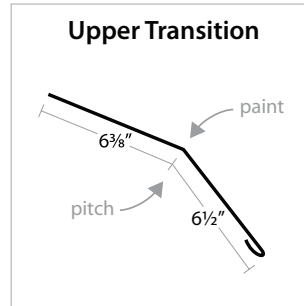
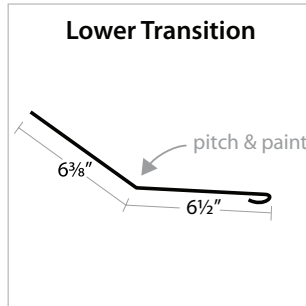
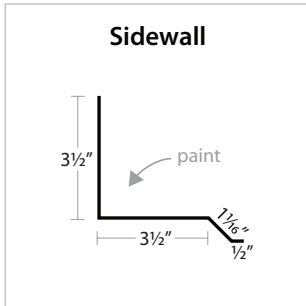
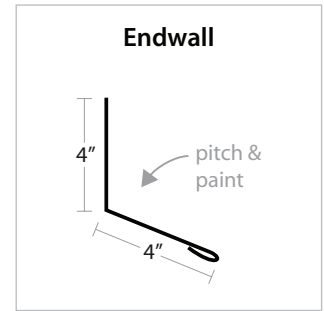
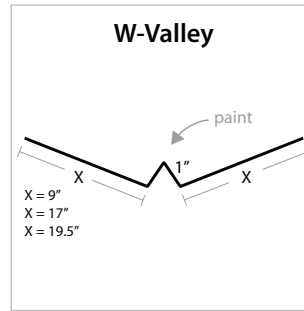
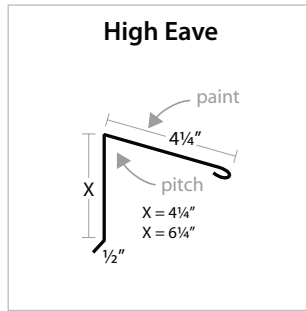
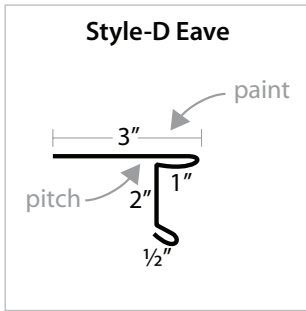
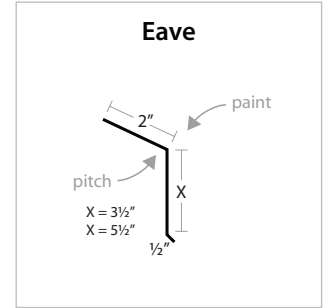
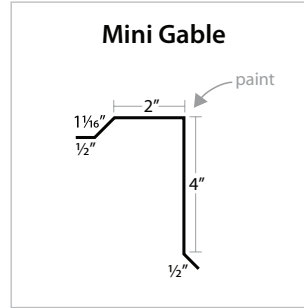
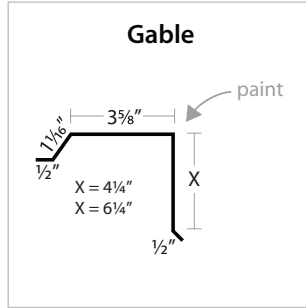
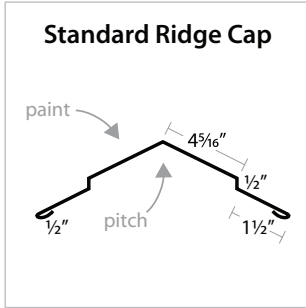

EPIC STEEL

TUF RIB

TRIM PROFILES

28 GA.
(10'1" / Stick)

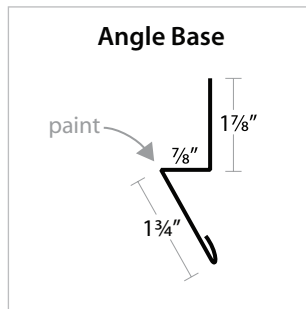
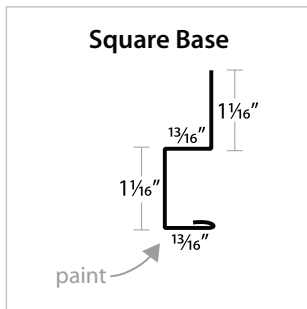
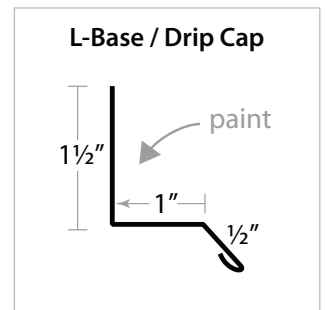
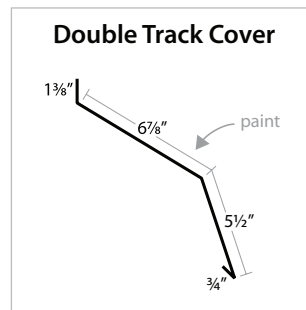
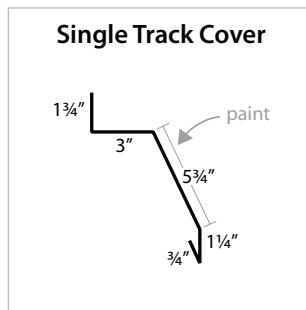
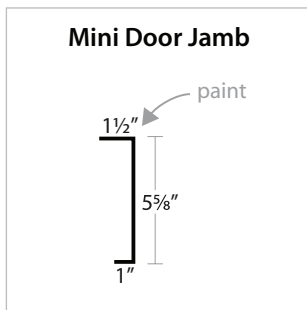
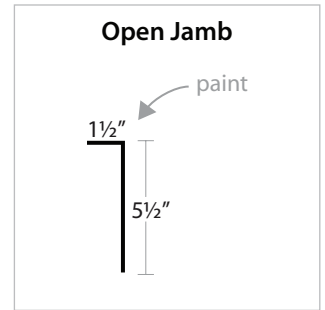
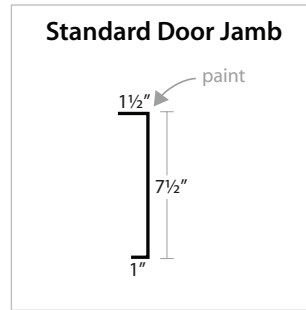
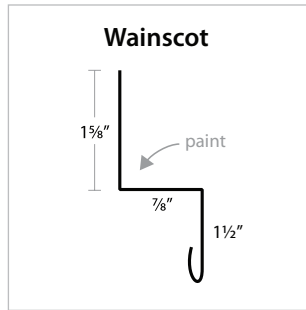
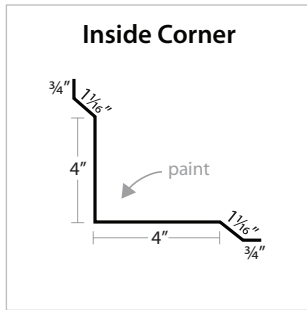

EPIC STEEL TUF RIB

VENTED RIDGE CAP

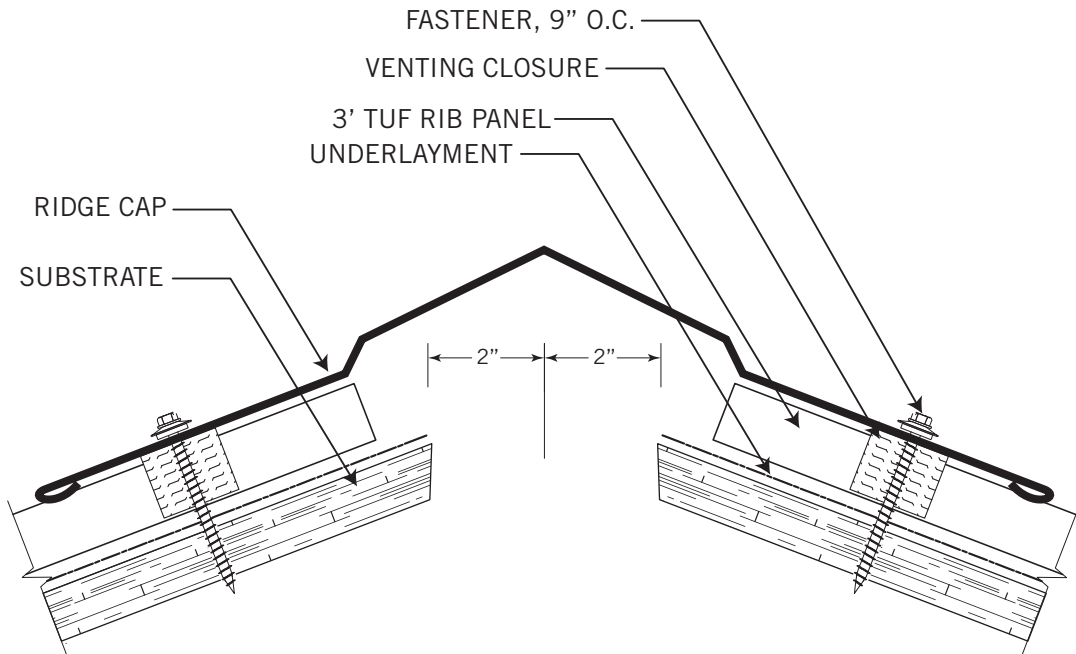

NON - VENTED RIDGE CAP

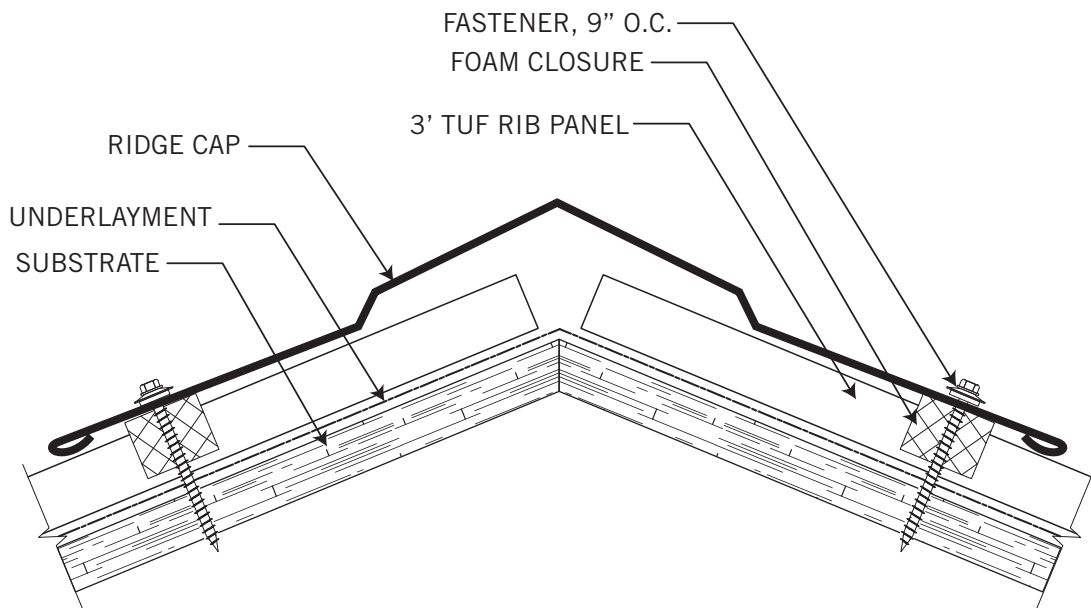

**Details are subject to change without notice.*

EPIC STEEL TUF RIB

HIP / RIDGE

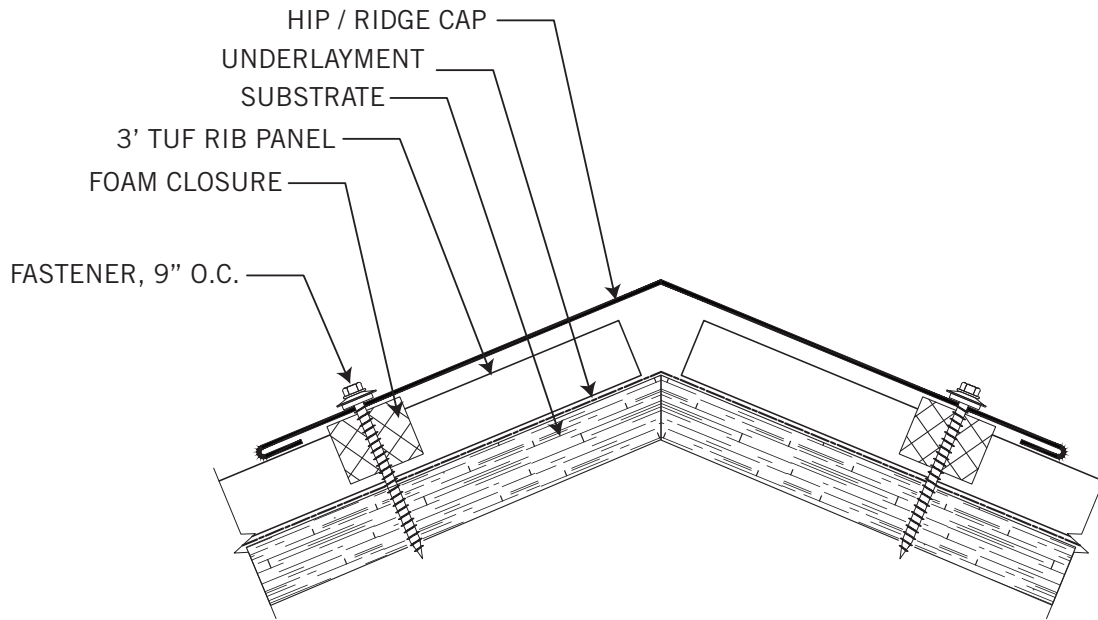

HIGH EAVE

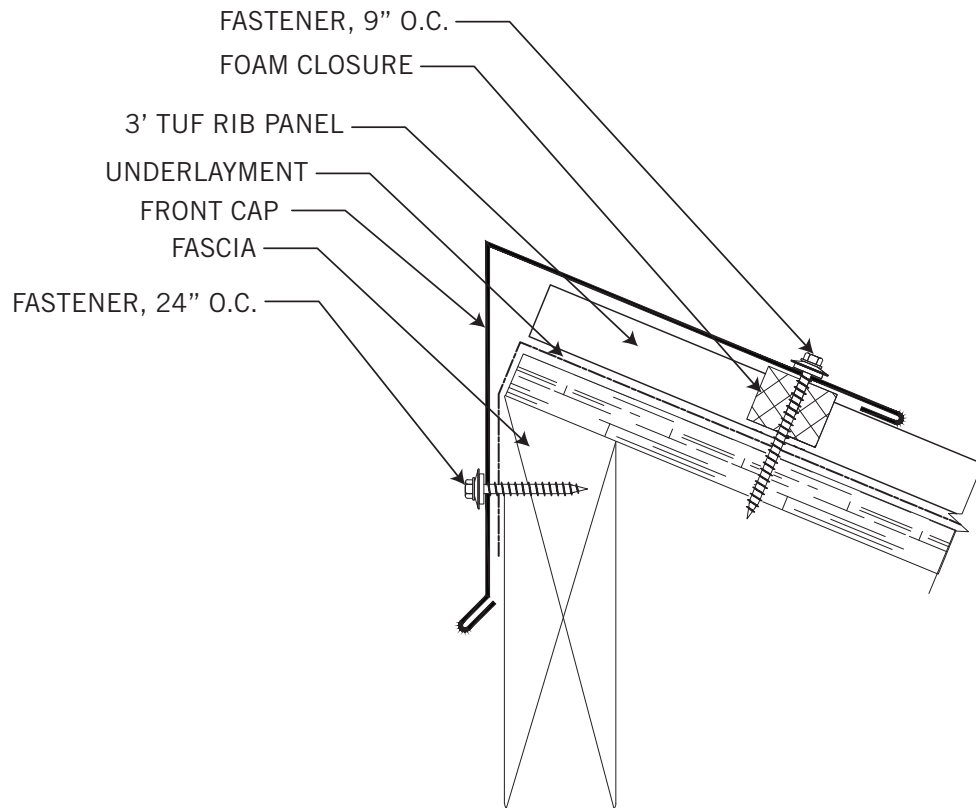

**Details are subject to change without notice.*

EPIC STEEL TUF RIB

GABLE

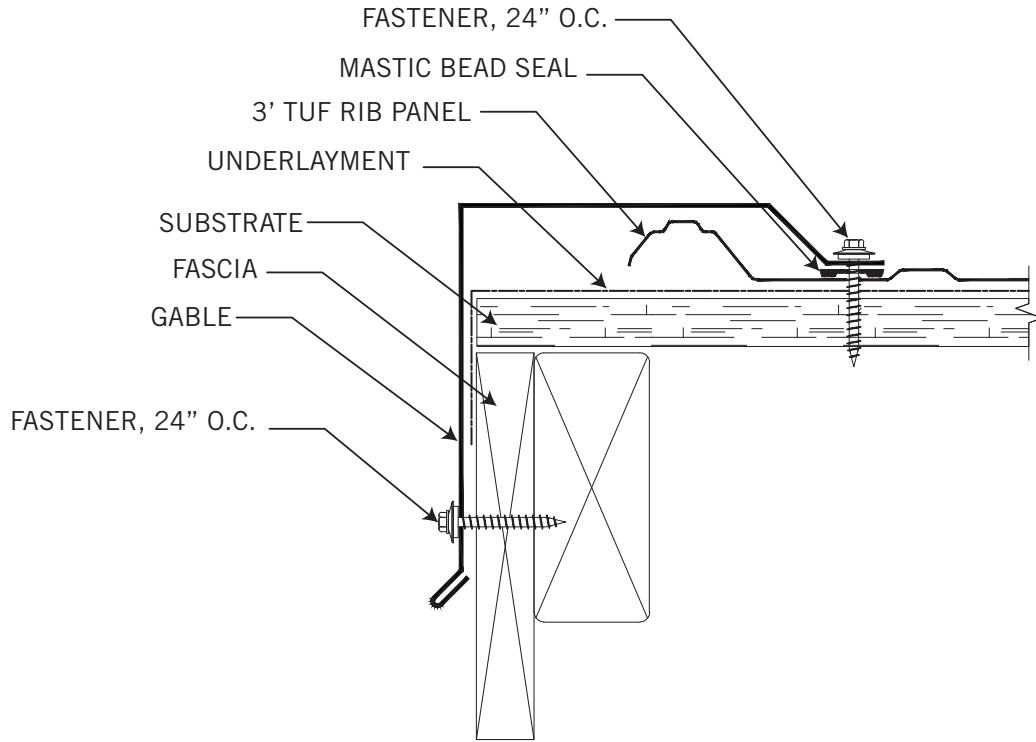

EAVE

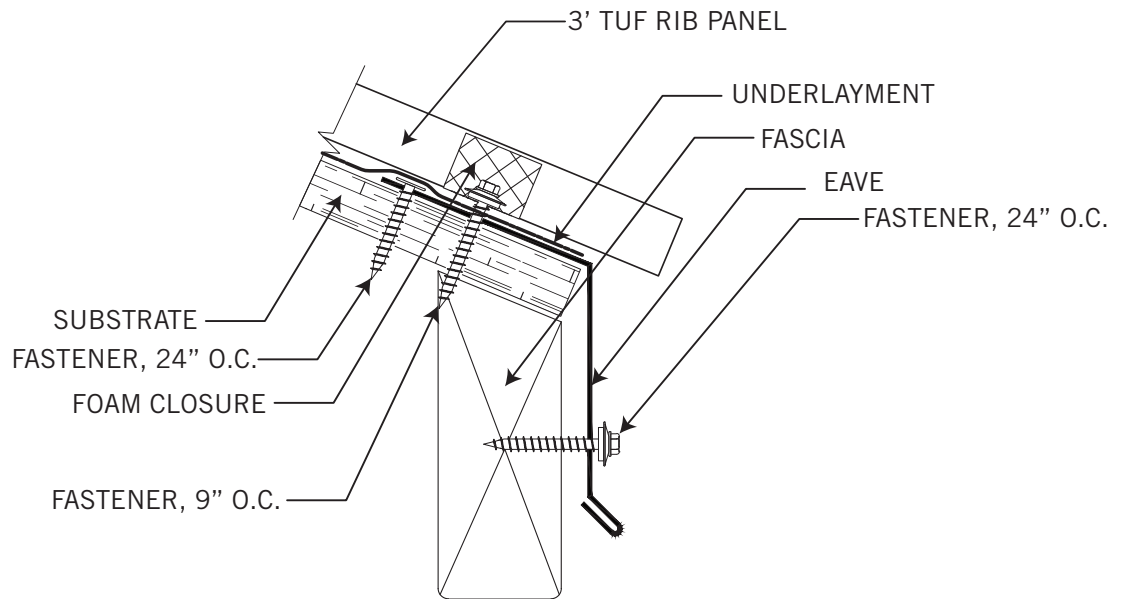

**Details are subject to change without notice.*

EPIC STEEL TUF RIB

F & J TRIM / 1/2" J TRIM

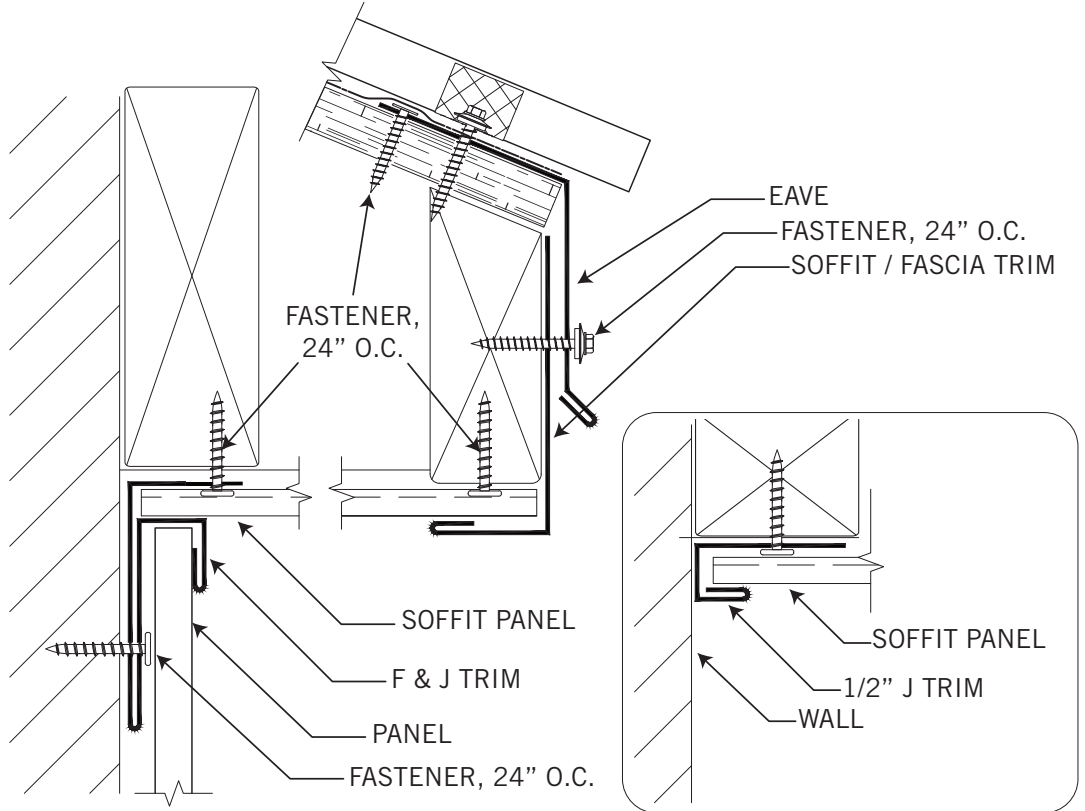

J CHANNEL ALT.

ENDWALL

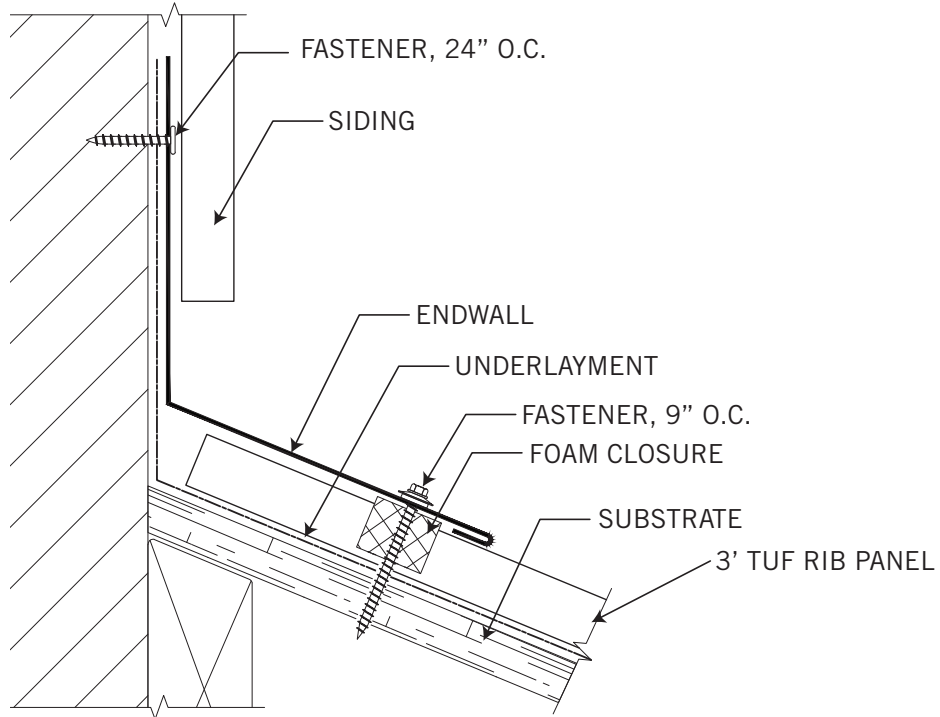

**Details are subject to change without notice.*

EPIC STEEL TUF RIB

SIDEWALL

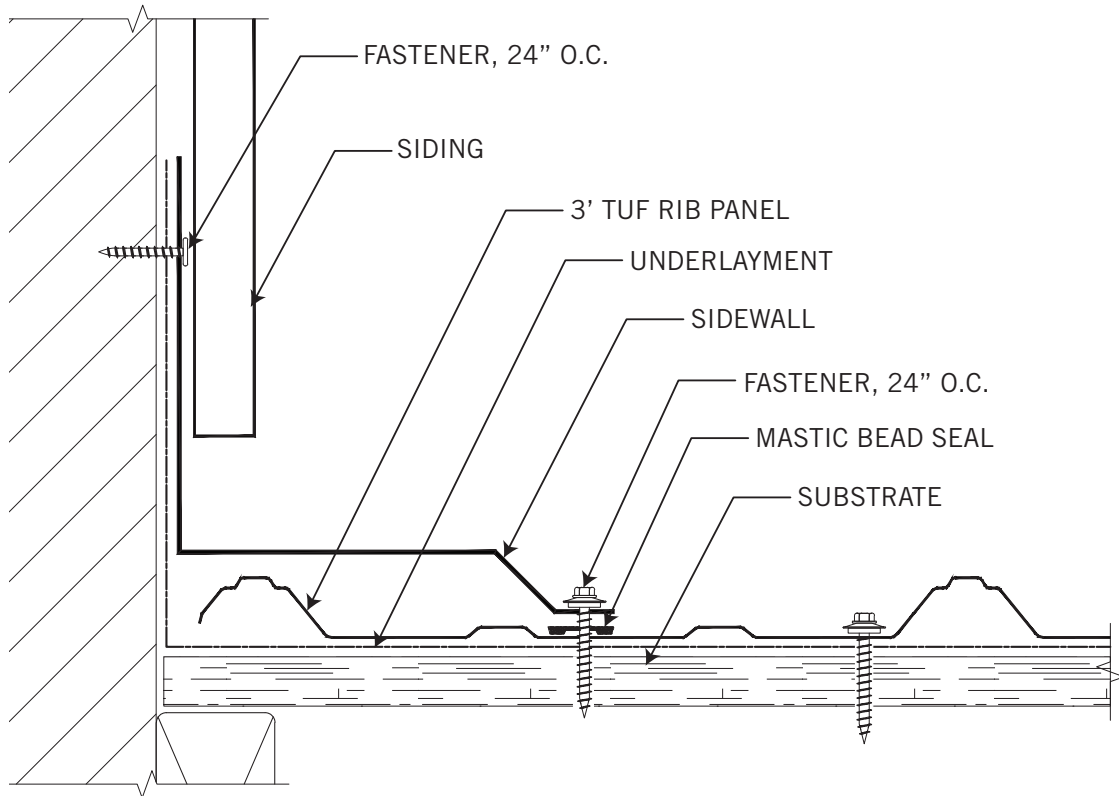

SNOW STOP

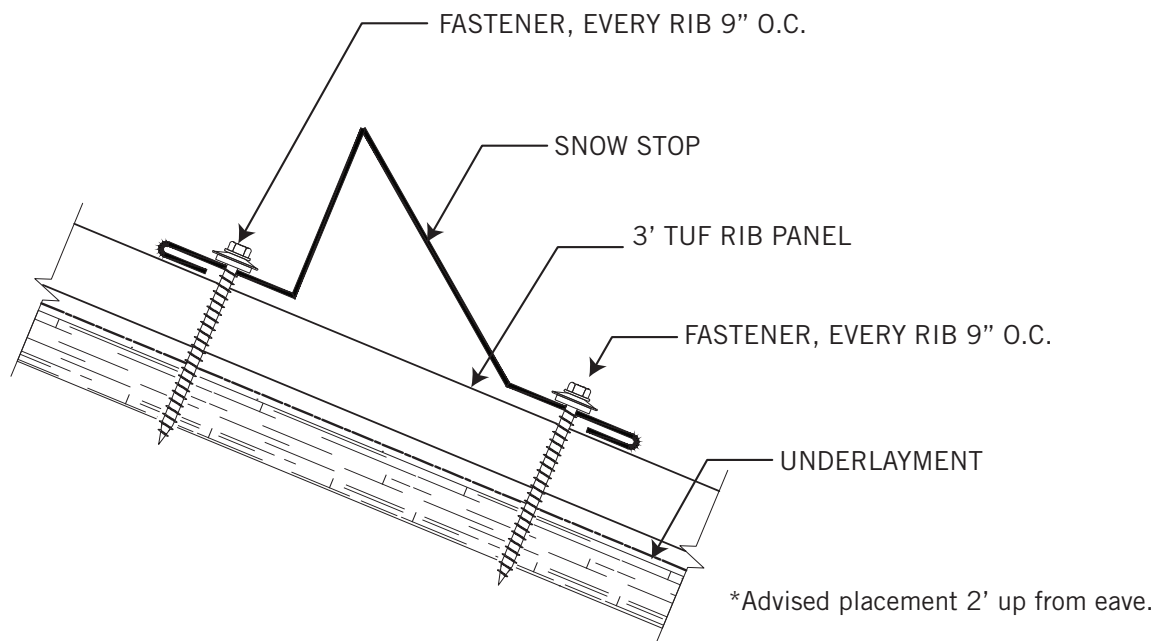

**Details are subject to change without notice.*

EPIC STEEL TUF RIB

INSIDE CORNER

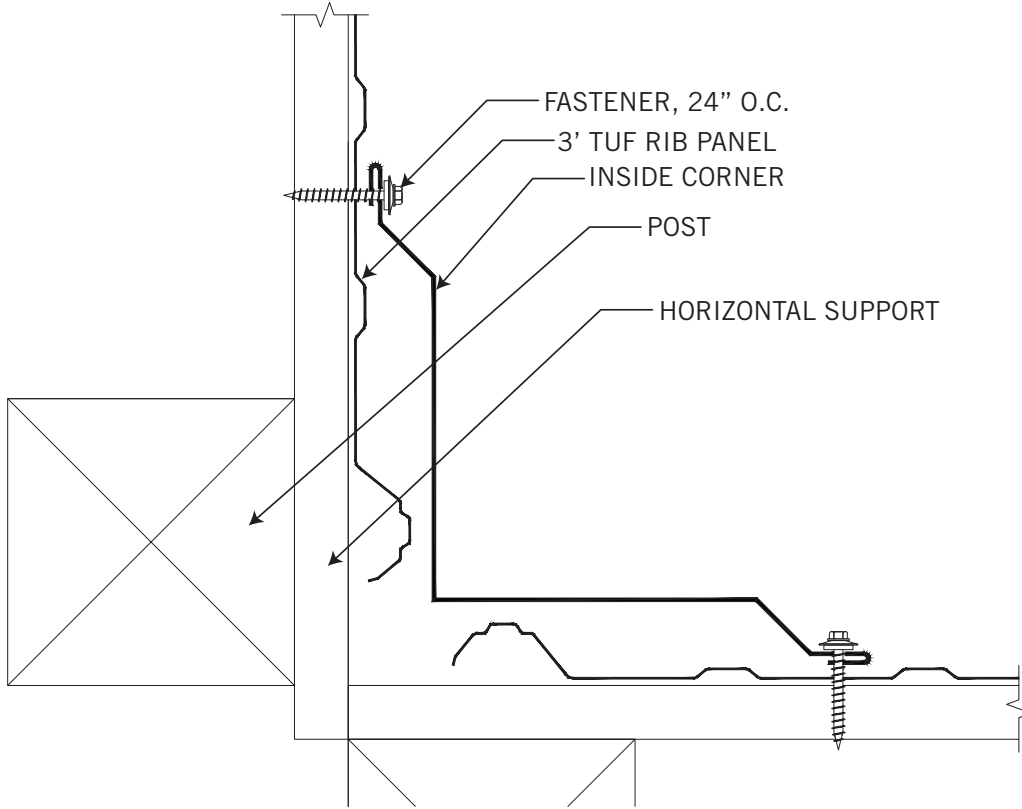

OUTSIDE CORNER

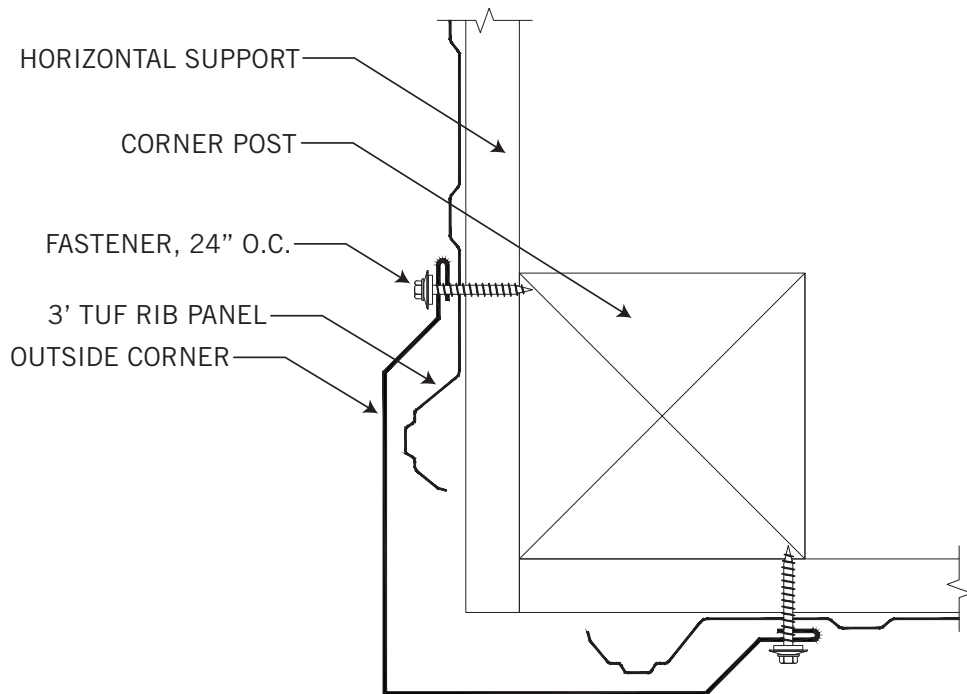

**Details are subject to change without notice.*

EPIC STEEL TUF RIB

L BASE / DRIP CAP

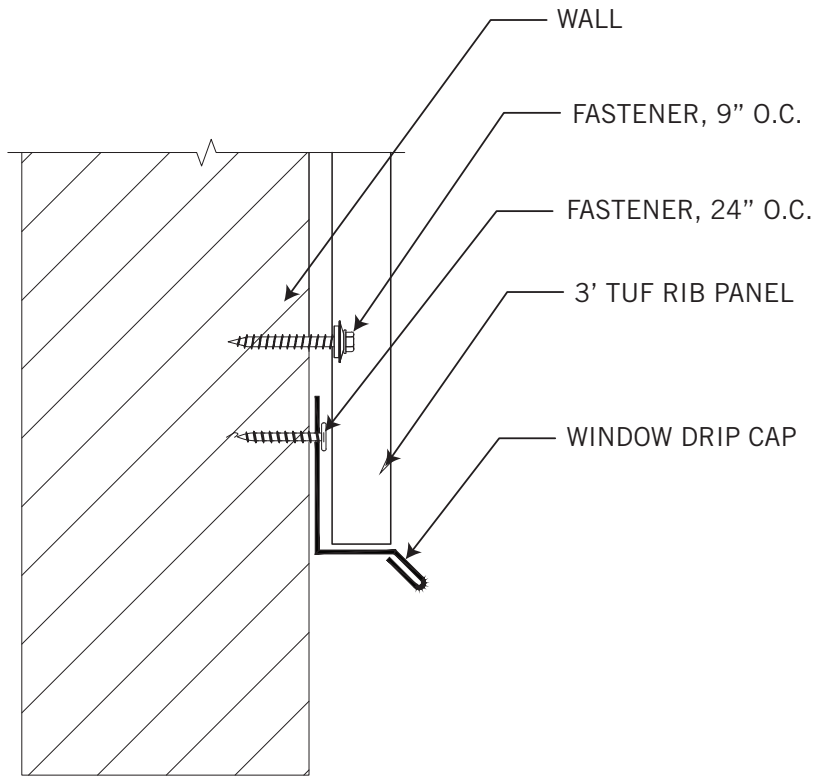

UPPER TRANSITION

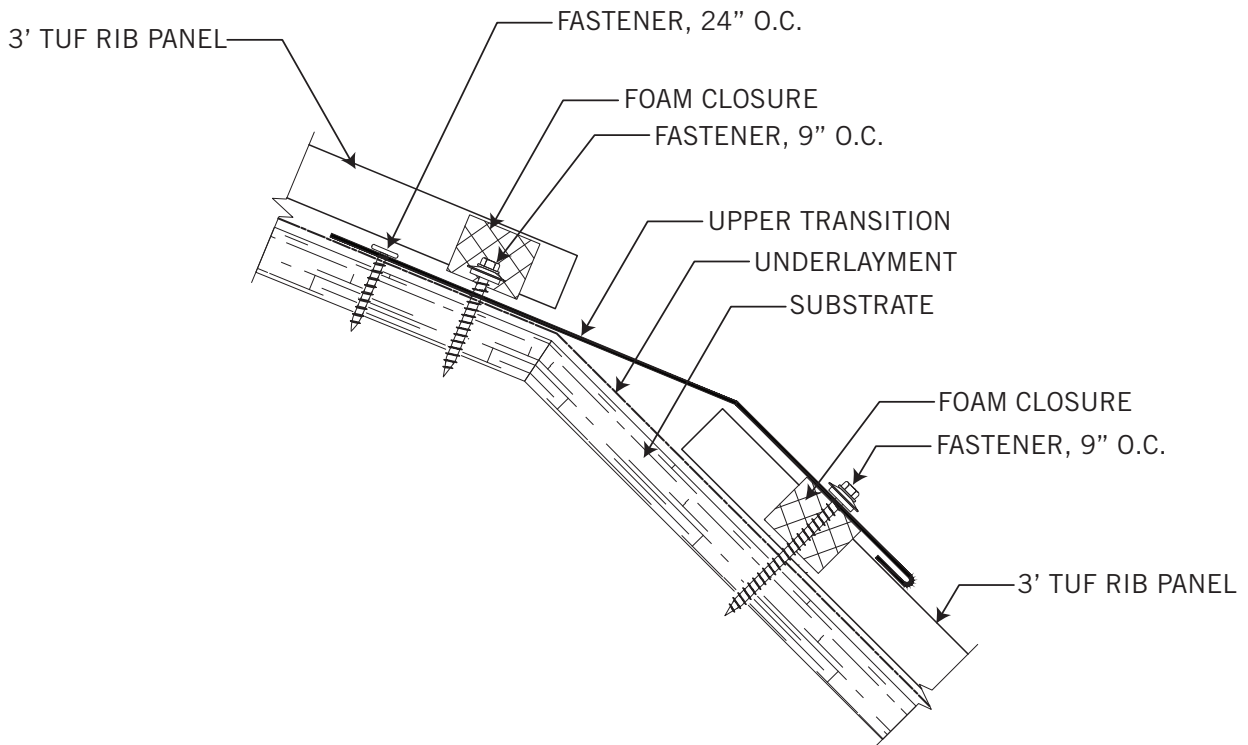

**Details are subject to change without notice.*

EPIC STEEL TUF RIB

LOWER TRANSITION

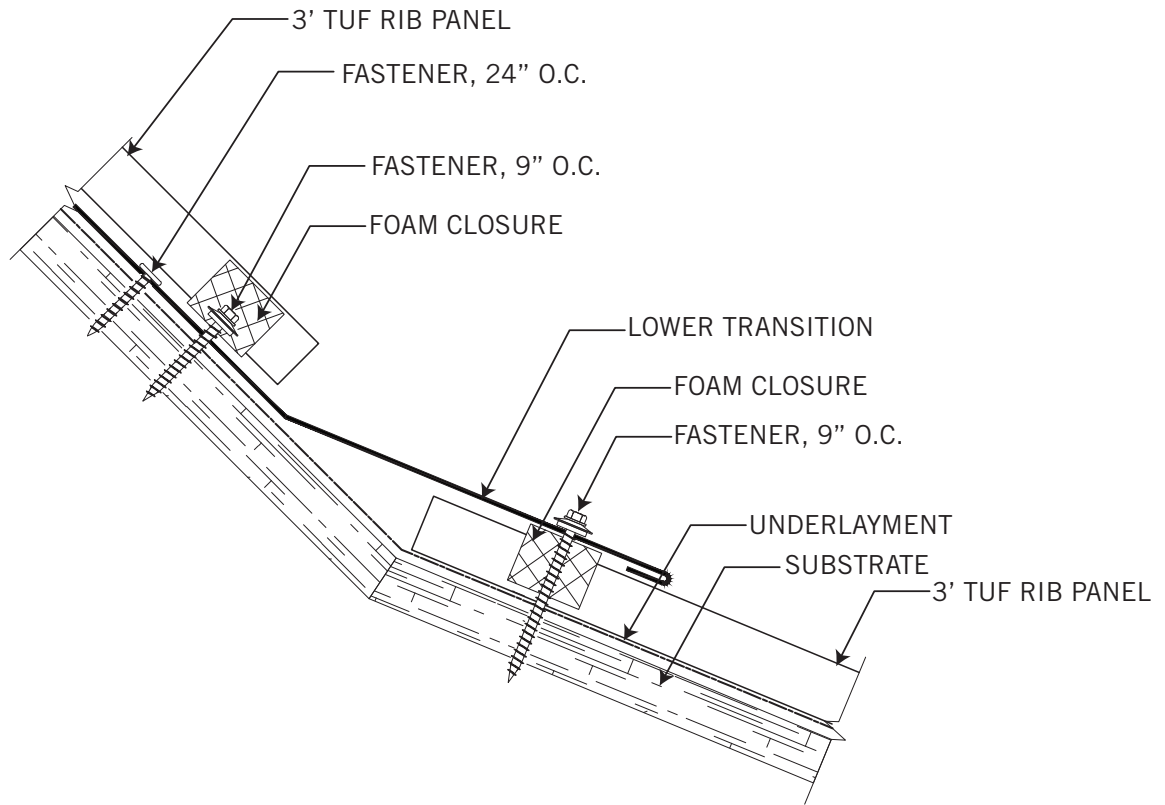

W- VALLEY

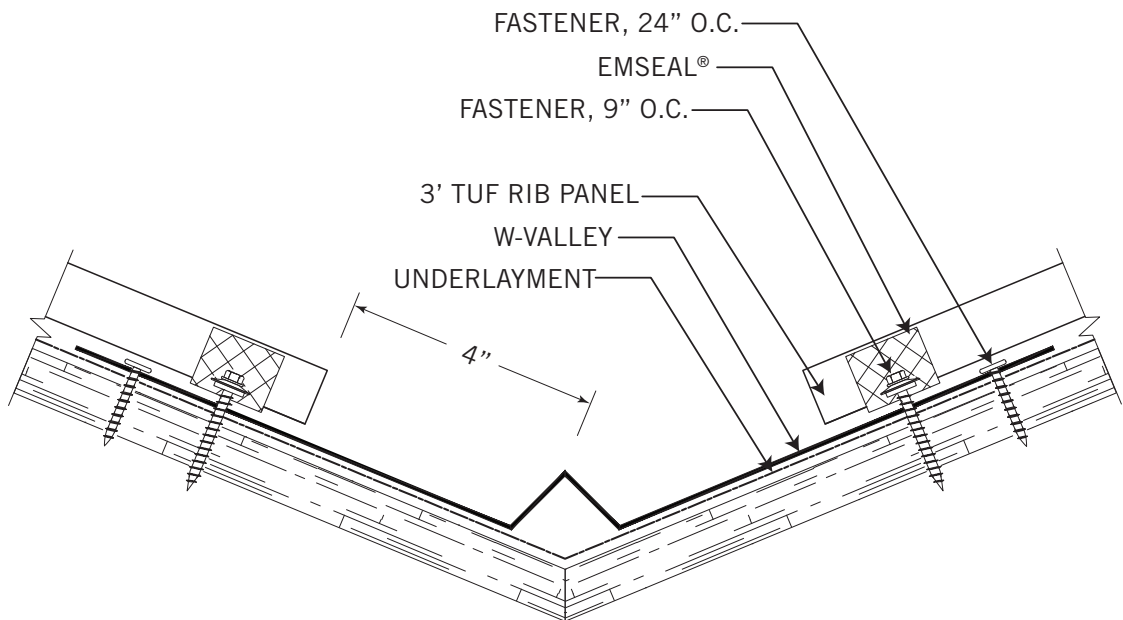

**Details are subject to change without notice.*

EPIC STEEL TUF RIB

ANGLE BASE

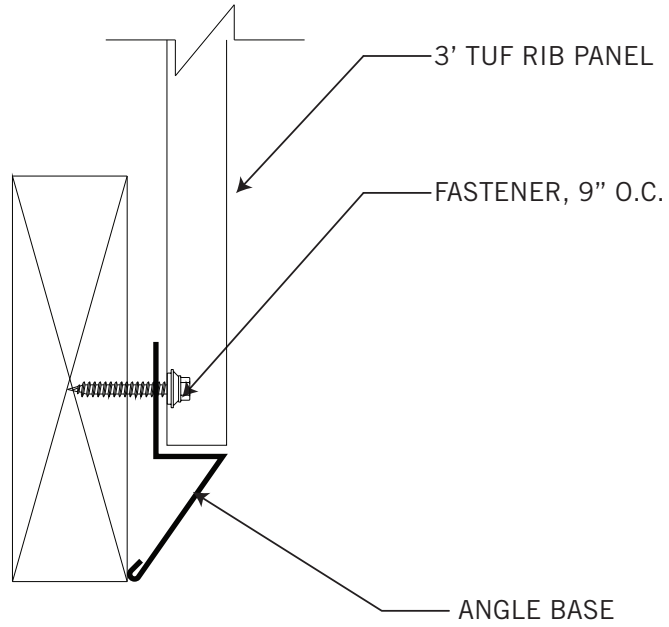

WAINSCOT/ Z-FLASHING

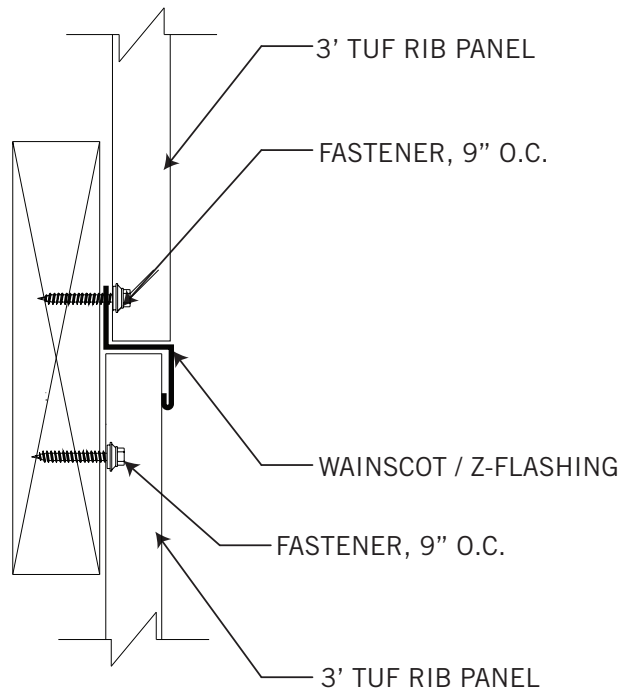

**Details are subject to change without notice.*

EPIC STEEL TUF RIB

PROW GABLE

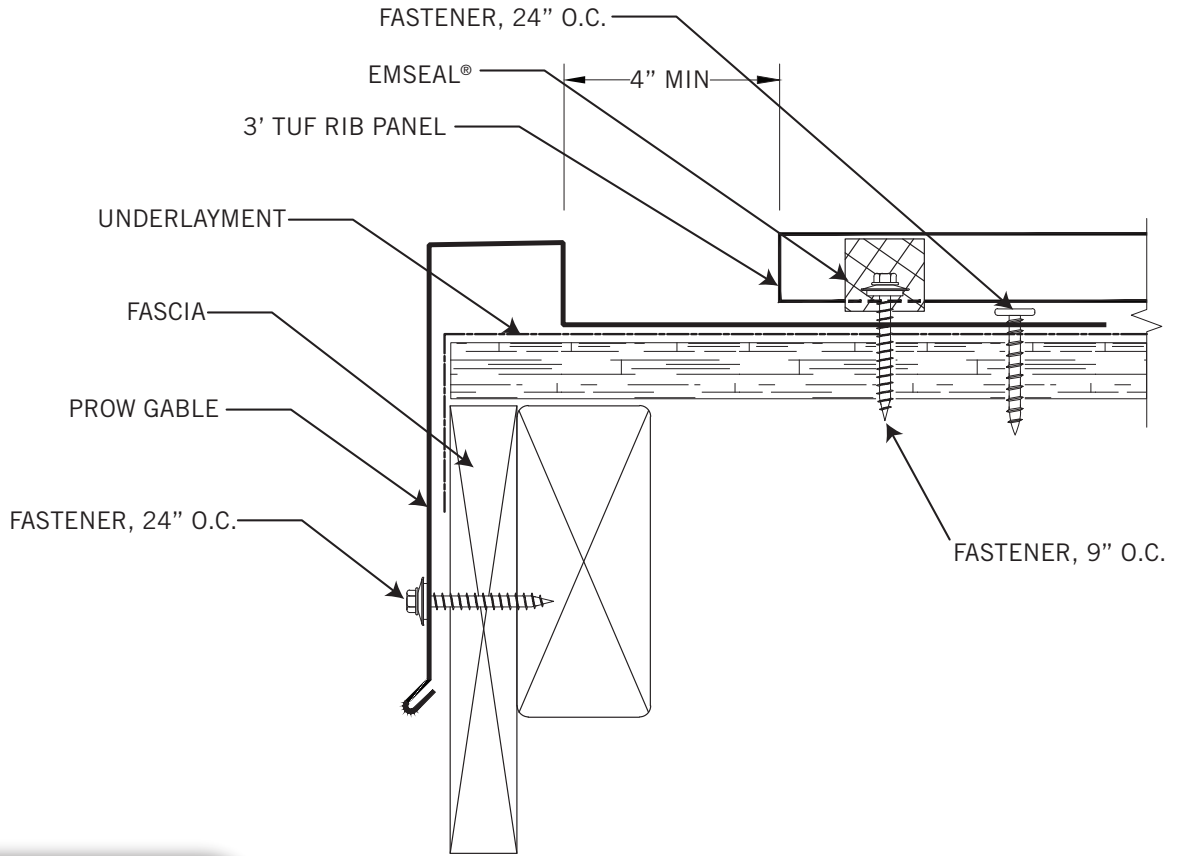

SQUARE BASE

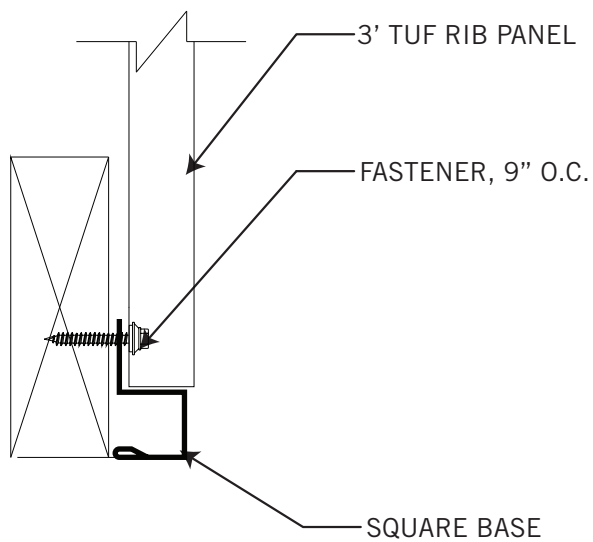

**Details are subject to change without notice.*

EPIC STEEL

TUF RIB

OVERALL DORMER

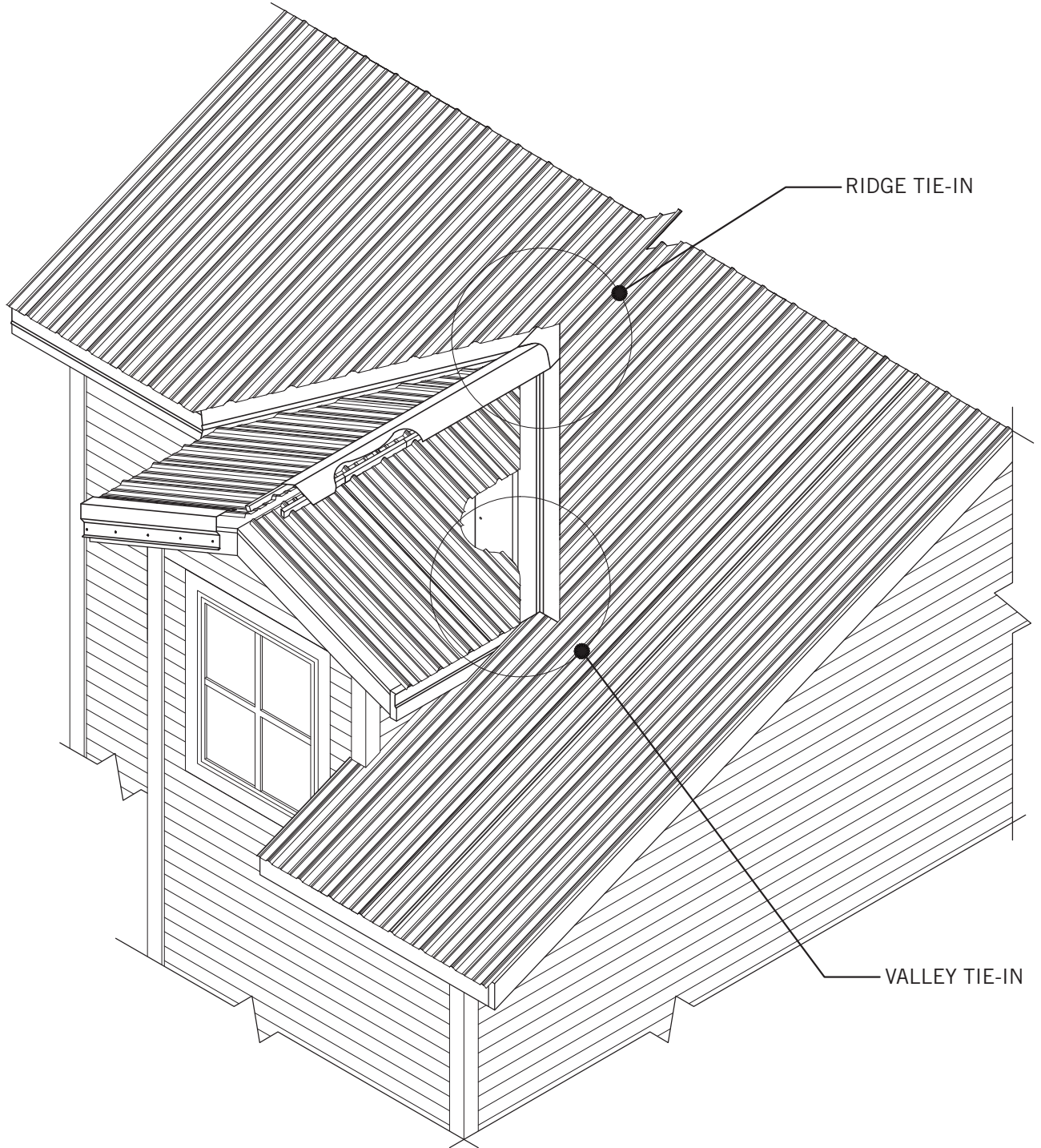

**Details are subject to change without notice.*

EPIC STEEL TUF RIB

RIDGE TIE-IN

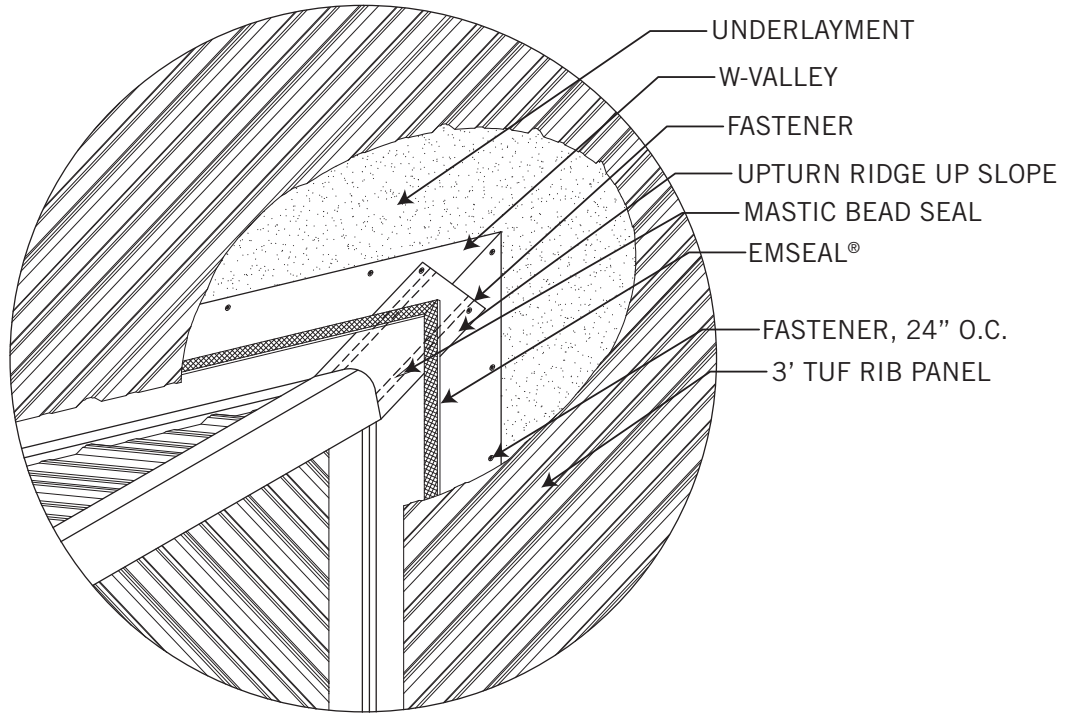

VALLEY TIE-IN

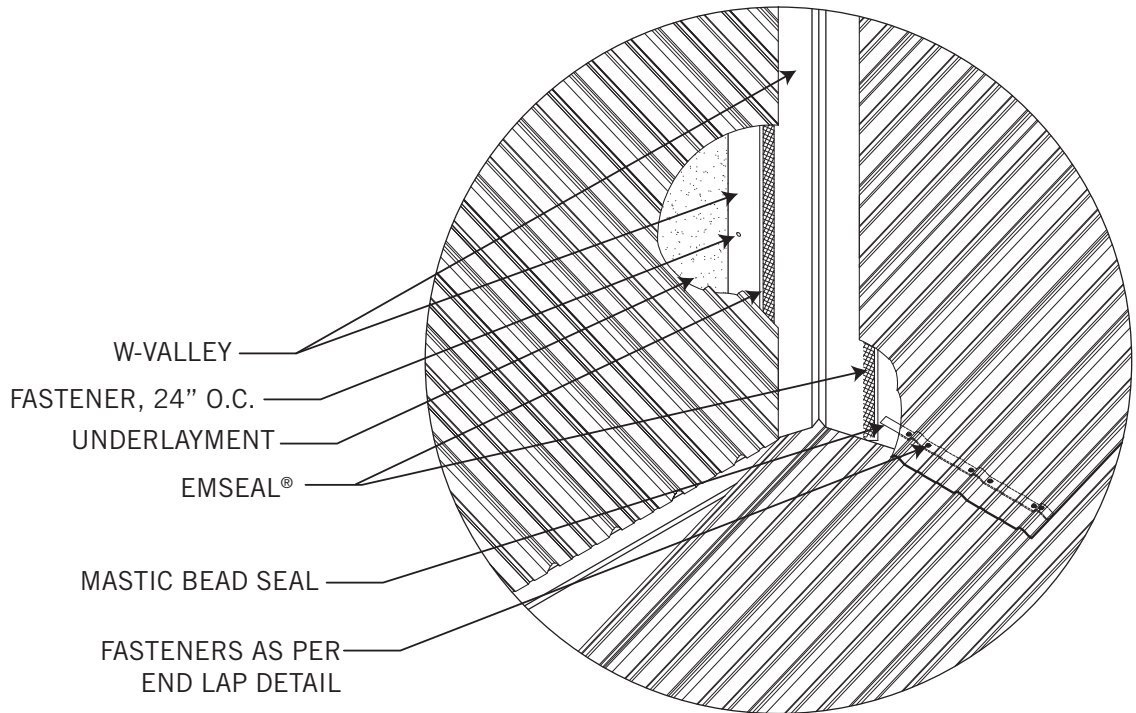

**Details are subject to change without notice.*